

4

3

2

1

THIS DRAWING IS UNPUBLISHED. RELEASED FOR PUBLICATION ,2003 .
 © COPYRIGHT 2003 BY AMP KOREA. ALL RIGHTS RESERVED.

LOC	DIST	REVISIONS					
		P	LTR	DESCRIPTION	DATE	DWN	APVD
DS			A	REDRAWN W/ CHANGE (FC00-0171-03)	16/DEC/03	YM	CS

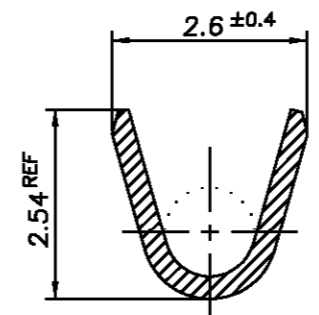
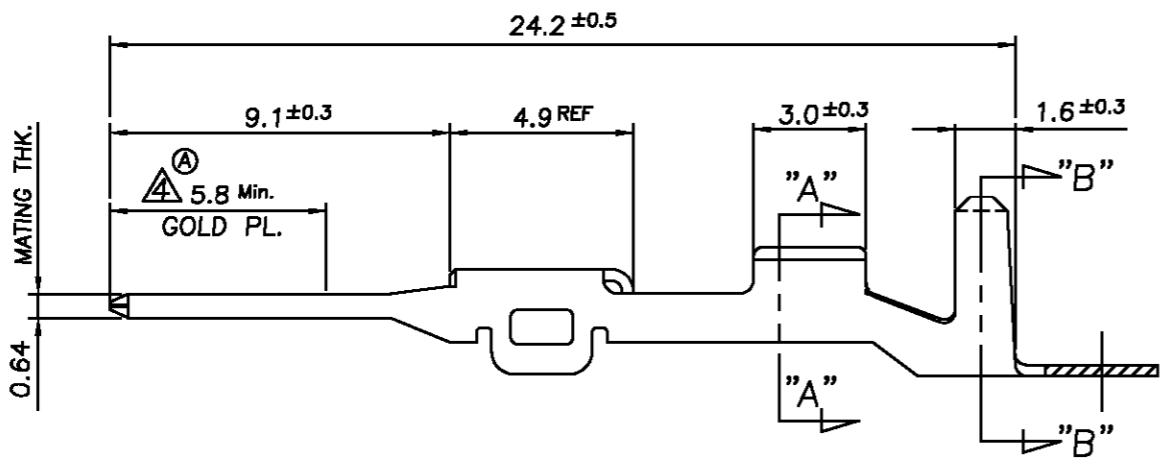
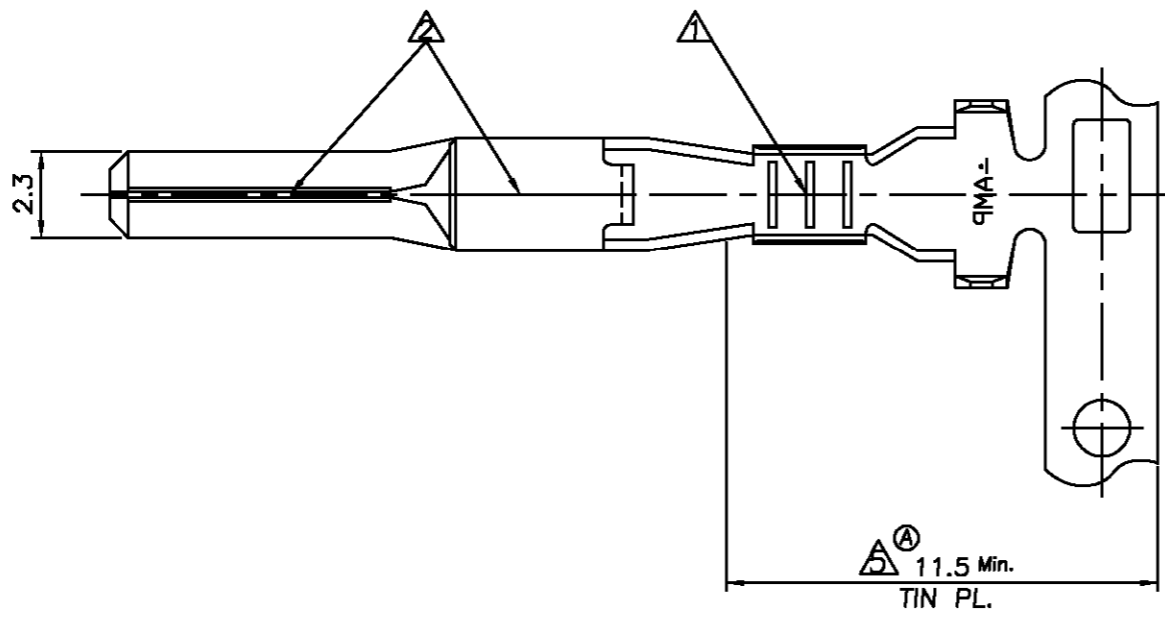

SECTION "A-A"
Scale 10/1

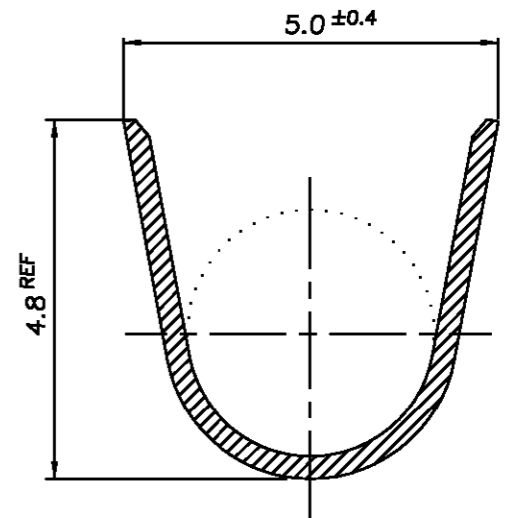

SECTION "B-B"
Scale 10/1

- * NOTES
- ▲ THREE SERRATIONS CENTERED IN WIRE BARREL.
 - ▲ 0.15 MAX GAP PERMISSIBLE.
 - 3 WIRE SIZE EQUIV CAVUS 0.3 ~ AVS 0.5 sqmm.

▲▲ SELECTIVE GOLD&TIN	MAKE FROM 936260-2	① 1- 936260 -1
PLAIN	BRASS Thk. 0.3mm	① 936260 -2
PRE-TINNED		936260 -1
FINISH	MATERIAL	PART NUMBER

THIS DRAWING IS CONTROLLED DOCUMENT FOR AMP KOREA. IT IS SUBJECT TO CHANGE AND THE CONTROLLING ENGINEERING ORGANIZATION SHOULD BE CONTACTED FOR THE LATEST REVISION.		DWN YM CHOI	AMP KOREA. kyungsan, korea		
DIMENSIONS: MM		CHK BM JANG			
TOLERANCES UNLESS OTHERWISE SPECIFIED:		APVD CS LEE	NAME .090 MLC SEALED TAB CONTACT		
0 <XX<10 ± 0.2 10<XX<30 ± 0.25 ANGLES ± 3°		PRODUCT SPEC			
MATERIAL SEE TABLE		APPLICATION SPEC	SIZE A3	CAGE CODE 00779	DRAWING NO 9 3 6 2 6 0
FINISH SEE TABLE		WEIGHT NET; 0.34gf	SCALE 5/1 SHEET 1 OF 1 REV A		